

SEKONIC

DIGITALMASTER

L-758DR

L-758D

L-758CINE

Operating Manual

1. Parts Designation

1. Light Meter Parts

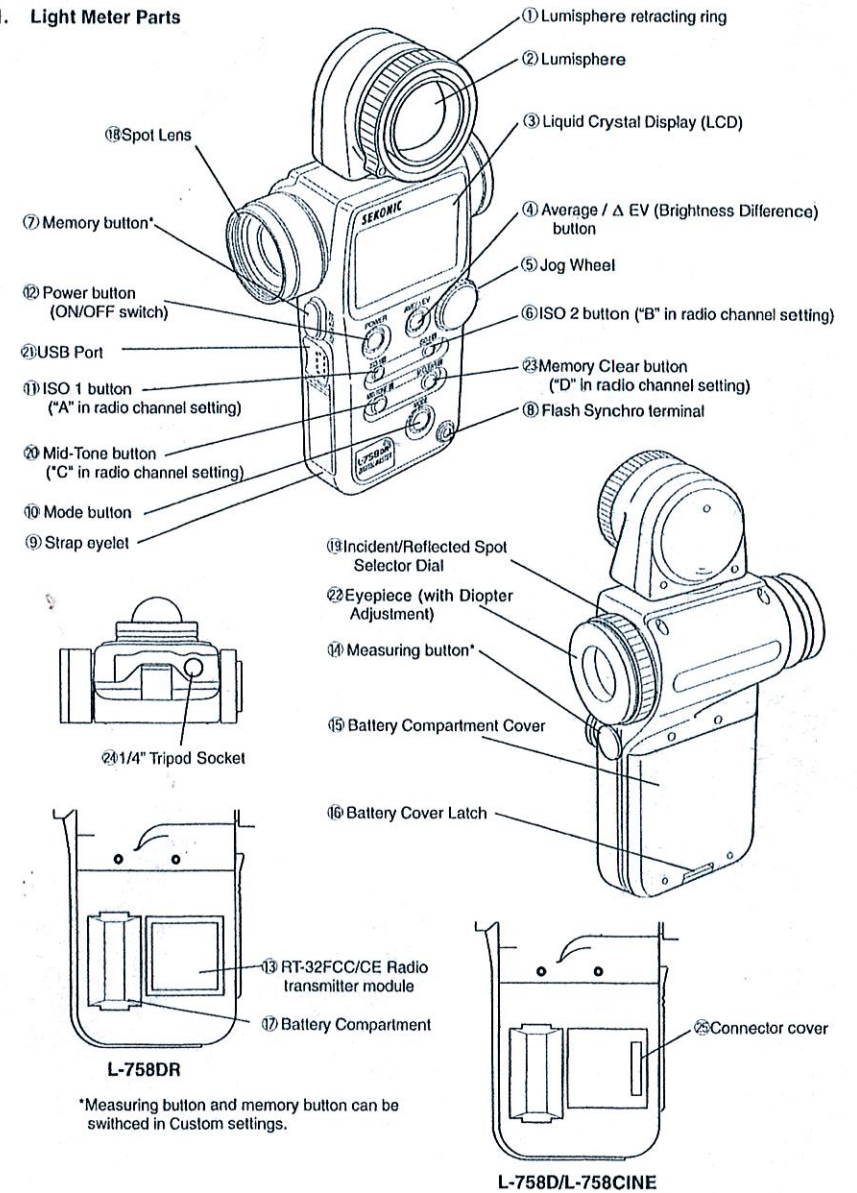

1. Parts Designation

2. Supplied Accessories

① Synchro Terminal Cap
(Attached to meter)



② Lens Cap
(Attached to meter)



③ CD-ROM for Software
(Data Transfer Software, USB driver,
Operating manual and Software guide)



④ Quick Guide (in Japanese/English)



⑤ Battery (CR-123A)



⑥ Strap



⑦ USB Cable

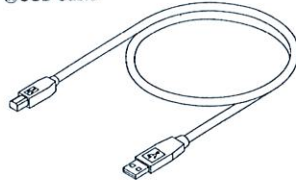

⑧ Sticker for Multi-key Operation and CS
(Custom Setting)



⑨ Operating Manual



⑩ Soft Case

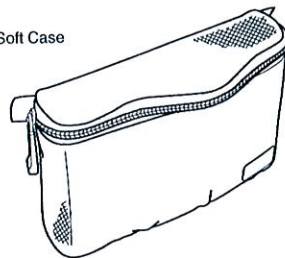

2. Explanation of the Liquid Crystal Display (LCD)

LCD for L-758DR/L-758D

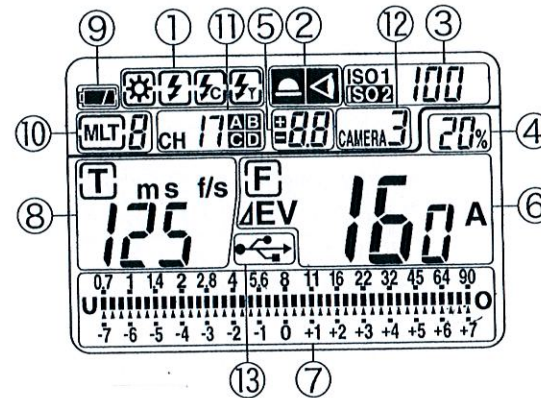

LCD for L-758CINE

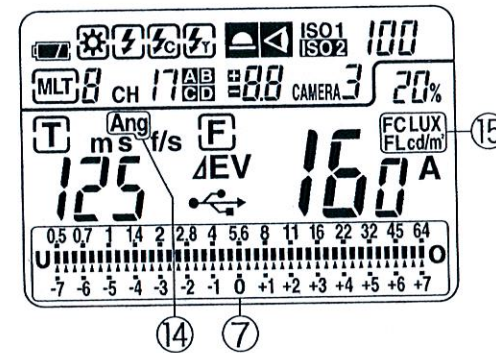

NOTE:

For explanation purposes, the display illustrated here shows all icons and readouts simultaneously. Actual LCD screen will not show all icon as above during normal use.

Auto Electro-Luminescent Display (EL)

- In low light (EV 6 or less), a green backlight will automatically illuminate the entire LCD.
- The LCD will not be automatically illuminated during measurements, in Cordless Flash or Wireless flash radio triggering mode.
- The Electro-luminescent backlight will automatically turn off 20 seconds after last operation.

2. Explanation of the Liquid Crystal Display

Display in viewfinder

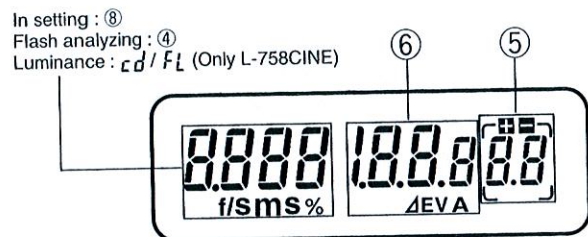

*Not displayed in Incident reading.

① Measuring Mode Icons

- Ambient (see page 15)
- Auto-Reset Cordless Flash (see page 22)
- Cord Flash (see page 21)
- Wireless flash radio triggering mode (see page 28)

② Incident / Reflected Spot Mode Icons (see page 11)

- Appears when in Incident mode
- Appears when in Reflected Spot mode

③ ISO Display (see page 8)

- ISO 1** Displays ISO 1 setting
- ISO 2** Displays second ISO setting when ISO 2 button is pressed

④ Flash Analyzing indicator (see page 27)

- %** 0 to 100% in 10% increments (percentage of the flash in the total exposure)

⑤ +/- Exposure/Calibration Compensation display (see page 36)

- Exposure compensation--- appears on the upper side of the main LCD.
- Calibration compensation--- appears only in the calibration setting mode.

⑥ Digital aperture value, Aperture Priority, EV Brightness Difference, Average function, EV display

- Appears when Aperture Priority (f/stop) mode is selected (see page 17)
- ΔEV** Appears when using Contrast function (see Page 32)
- A** Appears when using Averaging function and Contrast function (see page 32)
- EV** Appears when using EV mode (see page 18)

2. Explanation of the Liquid Crystal Display

⑦ Analog Scale

Displays measured values as icons along the apertures or Latitude EV scale. The scale is graduated in full or 1/3 stop increments for measurements. Memorized and averaged values are also display along the scale.

- Aperture scale (upper scale) displays in all mode except Aperture priority mode.
 - f 0.7 to f 90 in full stops appears in all modes except aperture priority mode (L-758)
 - f 0.5 to f 64 in full stops appears in all modes except aperture priority mode (L-758CINE)
- EV scale (lower scale) displays in all mode except Multiple flash cumulative mode.
 - +/-7 stops from Mid.Tone (0) appears in aperture priority mode, or other modes if selected.
- Value display scale

Appear to indicate last measured/ memorized/ averaged values and brightness difference value below the aperture scale or above the latitude scale depending on which scale has been selected.

U Appears when measurement is below display range

Blinks when measurement is below measurement range

O Appears when measurement is above display range

Blinks when measurement is above measurement range

Dynamic range/clipping point icons

Indicates dynamic range and clipping point of a selected camera exposure profiling.

⑧ Shutter priority indicator, shutter speed display for still photography or frames per second (f/s) for cinematography

Appears when Shutter Priority (T) is selected mode (see page 15)

m Appears when shutter speed is in minutes

S Appears when shutter speed is in full seconds

f/s Appears when cine speed is set in frames per second (see page 19)

⑨ Battery Power Indicator (see page 7)

⑩ Memory / Multiple Flash Indicator Display

Appears when Multi (cumulative) flash measurement mode is selected and shows the cumulated number of flash measurements (see page 24)

m Appears when reading is memorized and shows the number in memory (see page 31)

⑪ Radio triggering channel and Quad-triggering zone display (see page 28)

CH 17 Triggering Channel Numbers

ABCD Selective Quad-Triggering Zone

⑫ Camera profile selector display

⑬ USB icon

Appears when a USB cable is connected to the light meter and a computer.

2. Explanation of the Liquid Crystal Display

⑭ Shutter angle (L-758CINE)

Ang Appears when shutter angle is set to a value other than 180 degrees (see page 19)

⑮ Illuminance mark / Luminance mark (L-758CINE)

FC Appears when Foot-Candle is selected

LUX Appears when Lux is selected

FL Appears when Foot-Lambert is selected

cd/m² Appears when cd/m² is selected

3. Before Using

1. Attach the strap

Attach the Strap ⑳ by passing the small loop end through the eyelet ⑨ and passing the other end of strap through it.

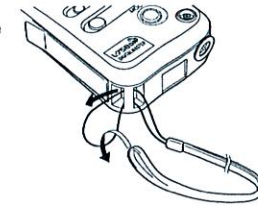

! WARNING

- To avoid a danger of strangulation, please keep the strap in a location where an infant cannot reach it and accidentally get the strap wrapped around his or her neck.

2. Inserting the battery

- Requires one 3.0 v CR123A lithium battery (included).
- Open the Battery compartment cover latch ⑮, and remove the Battery compartment cover ⑮.
- Insert the battery, observing the polarity with the +, - marks in the battery compartment ⑰.
- Align the tabs of the Battery compartment cover with the notches in the back of the meter, and press down to close the Battery compartment cover latch.

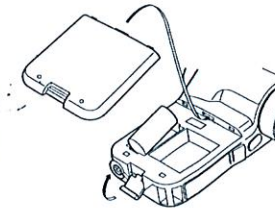

NOTE:

- To prevent loss of All-weather seal, be careful that dirt does not get stuck on the rubber seal and that the seal is not damaged.
- Remove battery if meter is not used for an extended period. Batteries can leak and damage the light meter. Dispose of used batteries properly.
- If the LCD does not light, check that the battery capacity is sufficient, and check that the battery positive and negative terminals are not reversed.
- The L-758D/L-758CINE has a connector for a plug-in radio transmitter module. Do not remove the connector cover unless you are installing the radio module, failure to do so could cause the electronic circuit board to be exposed to damaging static electricity.

3. Checking battery capacity

- When the Power button ⑫ is ON, the battery power indicator on the LCD is displayed.

 (Displayed) Battery power level is good.

 (Displayed) Battery power level is low. Have a spare battery ready.

 (Blinking) Replace battery immediately.

Reference:

- If the LCD screen turns off immediately after the display appears when power is first applied, that is an indication that the battery is dead. Please promptly replace the battery. We recommend you always have a spare battery on hand.
- A spare battery can be stored in a provided compartment of the L-758DR's case (see sticker "OPEN END TO BACK").
- Under our testing condition, the battery life is approximately 60 hours with continuous use under normal temperature.
- The battery supplied with this light meter, may not be able to meet battery life mentioned above because of undetermined shelf life or storage condition.

3. Before Using

4. Replacing the battery during measurement or when using the memory function

1. Always turn the power OFF before replacing the battery. If the battery is removed with the power ON, measurements and settings in memory can no longer be recalled.
2. If after replacing the battery, or during measurements, strange screens (displays that have not been set) appear on the LCD, or nothing happens, no matter what button is pushed, remove the battery and wait at least ten seconds and then replace the battery. This allows the software to automatically reset.



WARNING:

- Never place batteries in fire, short, disassemble, or heat them. The batteries might break down, and cause an accident, injury or pollute the environment.

NOTE:

- A three second pause between power on and off is recommended to avoid damage to the meter.

5. Auto Power Off function

1. To conserve battery power, the meter will turn off about twenty minutes after last use.
2. Whether the Auto Power Saving feature turns the power off or the Power button ⑫ is pressed, the settings and measured values remain stored in memory. When the Power button is pressed again the last settings are displayed.

Reference:

- The power shuts off automatically after 1 minute when the power button is pressed and held.
- Auto power off time is adjustable in Custom settings. (See page 40 for details)

6. Setting ISO 1 sensitivity

1. Hold down the ISO1 button ⑪ and turn the Jog wheel ⑤ to select the desired ISO sensitivity.
2. You can also change the ISO sensitivity after taking measurements. The new value is automatically displayed.

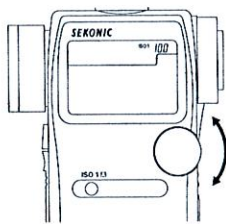

7. Setting ISO 2 sensitivity

1. This feature is useful when using a different ISO sensitivity (film or digital), Polaroid proofing film, or for exposure correction (when using a filter, extension tubes, bellows factor or another camera etc.).
2. Hold down the ISO 2 button ⑬ and turn the Jog wheel to select the desired ISO sensitivity.
3. Once this is set, after taking a measurement, the measured value for the second ISO sensitivity will be displayed when the ISO 2 button is pressed.
4. You can also change the second ISO sensitivity after taking measurements. The new value is automatically displayed.

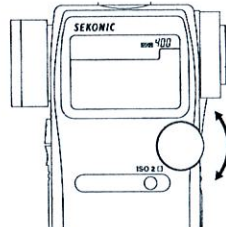

Reference:

- The following settings are possible when using custom setting function P40.
 1. It is possible to set ISO 2 for Filter compensation. These values can be set within a range of ± 5 EV in 1/10 steps and are display in the ISO 2 area.
 2. Filter factor number compensation enables you to set seven types of filters frequently used in the CINE industry. (Kodak Wratten Filters)(L-758CINE only)

3. Before Using

8. Jog Wheel Lock or Lock Off

1. Hold down the Mode button ⑩ and ISO1 button ⑪ and "LOC" will appear to indicate that the Jog Wheel is locked. The last measurement is held until the lock is released, even if the Jog wheel ⑤ is accidentally moved.

However, if the measurement button ⑭ is pressed, a new measurement is displayed with the same locked settings.

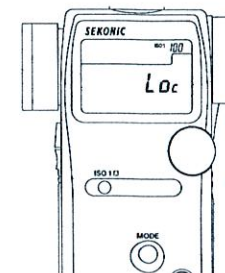

2. To release the Jog Wheel lock, perform the same operation for the Jog Wheel lock, Hold down the Mode set button and ISO1 button and "Off" will appear to indicate that the Jog Wheel lock is released.

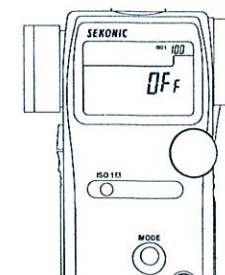

Reference:

- If power of the meter is turned off or auto off is activated when in the Jog Wheel locked position, the lock function will continue operating when the meter is turned on again.

3. Before Using

9. Setting the Measuring and Memory button configuration

In the custom settings mode (refer to P40), the Measuring button and the Memory button can be set as follows.

1. For Incident measuring

The Measuring button and Memory button is set in the standard configuration. (Described on Page 1 in Light Meter Parts) Please make sure that the default value in the Custom settings mode is set to .(Custom No.17, Item No. 0)

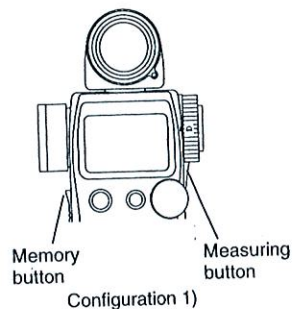

2. For Reflected (Spot) measuring

If the standard buttons configuration is inconvenient for spot metering, the Measuring button and Memory button can be switched. Set the Custom settings mode to Custom No. 17, Item No. 1

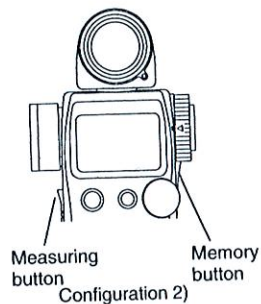

3. For both Incident/Reflected (Spot) measuring simultaneously

You can set the buttons configuration automatically according to light measuring method. In incident mode, the buttons configuration is 1), but in reflected mode, the buttons configuration is 2). For this setting, please set (Custom settings mode No. 17 and Item No 2).

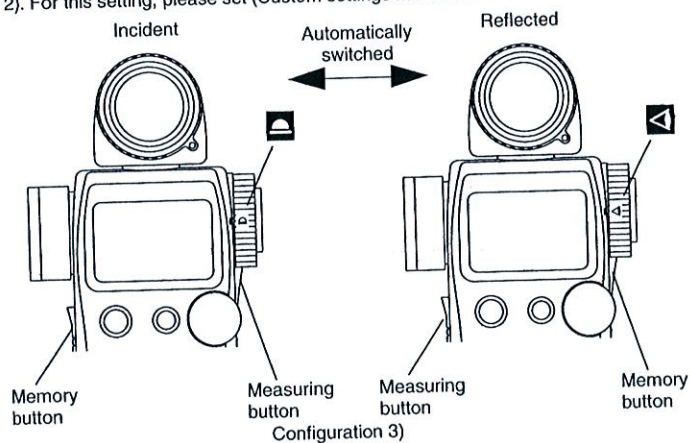

4. Basic Operation

1. Incident or reflected spot measuring

- To set for either incident or reflected light operation, turn the Incident / Reflected Spot Selector Dial (9) on the eye piece, to the desired position (☐ or ◀ mark) until it clicks.

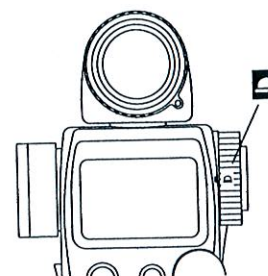

Incident operation

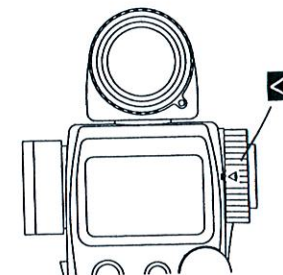

Reflected Spot operation

- When incident operation is selected, the ☐ mark will blink for ten seconds and when Reflected Spot operation is selected the ◀ mark will blink for ten seconds on the LCD.

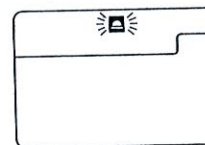

Incident operation

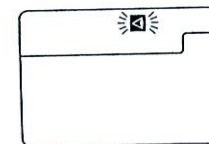

Reflected Spot operation

NOTE:

- Before taking measurements, always make sure that the desired measurement mode (☐ or ◀) is chosen by checking the LCD or that the Incident/Reflected Spot Selector Dial is clicked in proper position.
- Do not rotate the Spot lens ring. There is danger of damage.

4. Basic Operation

2. Setting measuring mode

1. Hold down the Mode button (10) and turn the Jog wheel (5) to select the desired mode. The mode switching sequence is shown in the chart below:

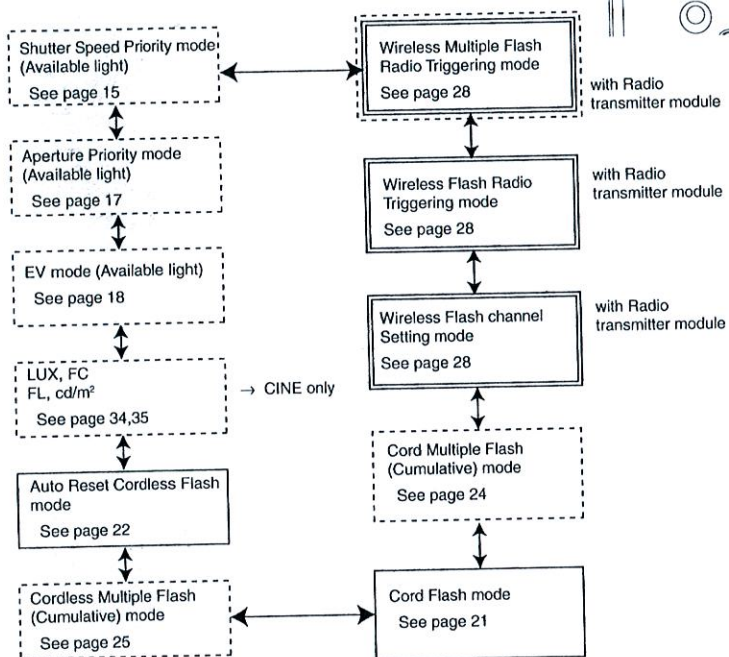

2. Modes enclosed in dotted lines [] can only be selected with custom setting. (See page 40)
3. Modes enclosed in [] lines can only be selected with L-758DR. For L-758D and L-758CINE, they can be selected when Optional Radio Transmitter Module is installed. (See page 28)
4. In addition to exposure reading, L-758CINE displays FC or LUX in incident light mode, and FL or cd/m^2 in reflected light mode. (See page 34)

Reference:

- Available light is continuous light like natural light (sunlight) or tungsten lamps and fluorescent lamps like pulsing light sources.
- Flash light is a brief, intense burst of light made by such as electronic flash units or flash bulbs.

4. Basic Operation

3. Incident Measurement Mode

Incident light measuring is the measurement method that employs either the Lumisphere or Lumidisc functions. Measurements should be with the Lumisphere aimed towards the camera direction from the subject position.



1. You can select extended or retracted lumisphere measuring positions by rotating the Lumisphere retracting ring (1) (clockwise or counter-clockwise) until it clicks into position.

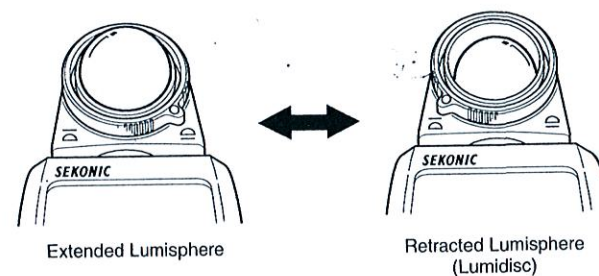

2. When the Lumisphere is extended. (3-D Light Measurement)
This is used to measure people, buildings, and other three dimensional objects. Measurements are basically made by the method of measuring with the lumisphere aimed in the camera direction (more precisely, in the direction of the lens axis) at the position of the subject.
3. When the Lumisphere is retracted (flat diffuser function)
This is used to measure manuscripts, paintings or other flat copy. It can also be used for Contrast function (see page 32) or measuring illumination (see page 34).

NOTE:

- If the light meter is used with the Lumisphere retracting ring in a middle position, distributed light quality will change, and suitable measurements cannot be made.
- Do not push the Lumisphere down with your finger or hand. Always use the Lumisphere retracting ring.
- If the lumisphere becomes soiled, wipe it with a soft, dry cloth. Organic solutions (paint thinner, benzene, etc.) must not be used under any circumstances.

4. Basic Operation

4. Reflected Measurement Mode (spot metering)

This method measures the brightness (luminance) of the light reflected from the subject. It is useful for distant objects such as landscapes, when you cannot go to the position of the subject, or for metering subjects that generate light (neon signs, etc.), highly reflective surfaces or translucent subjects (stained glass, etc.).



1. Take the measurement by aligning the circle inside the viewfinder with the subject area to be measured.
2. The black circle (A) in the finder indicates the measurement range. The light receiving angle is 1 degree.

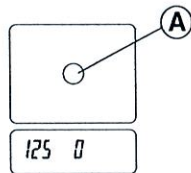

(Display in spot viewfinder)

< Diopter Adjustment >

Turn the eyepiece (22) and adjust the diopter so that the circle in the finder is clearly visible when you look into the finder.

< Step-Up Ring (Lens Hood) > (optional)

The step-up ring (30.5mm → 40.5mm), available as an optional accessory, makes it possible to mount step-up rings and filters. This simplifies the setting of exposure without the troublesome correction calculation of polarizing filters, etc. (see page 52)

The step-up ring can also be used as a lens hood to prevent lens flare and erroneous light measurements from glare, it also protects the spot lens from scratching, soiling, etc.

5. Measurement

1. Measuring ambient light

In this measurement mode, we have the choice of shutter priority mode, aperture priority mode or EV mode. Hold down the Mode button (10) and turn the Jog wheel (5) to select ambient measurement mode (8).

1-1 Shutter Speed Priority mode

1. Hold down the Mode button (10) and turn the Jog wheel (5) to select Shutter Speed Priority mode (T).

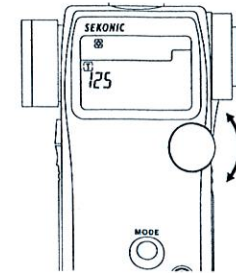

2. Turn the Jog wheel to set the desired shutter speed.

3. Press the Measuring button (14) to take a measurement. Release the Measuring button to complete the measurement. The measured value (aperture value) at that time will be displayed.

While pressing the Measuring button, the meter measures continuously until it is released.

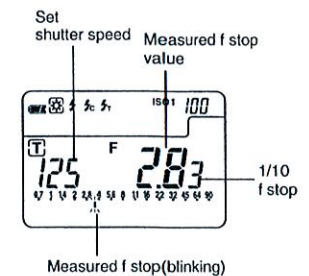

Reference:

- It is possible to switch between full, 1/2 and 1/3 shutter speeds with custom setting (see page 36).
- You can set shutter speeds from 30 minutes to 1/8000 seconds. After 1/8000 the shutter speeds of 1/200 and 1/400 can be set.
- After taking a measurement, the F stop value corresponding to the shutter speed is displayed. The measured F stop value automatically corresponds to the shutter speed if the shutter speed is changed by rotating Jog wheel.
- The L-758DR/758D displays the measured aperture value in either full or 1/3 stop increments on the analog scale from f/0.7 to 90, while L-758 CINE displays it in either full or 1/3 stop increments on the analog scale from F0.5 to F64.
- You can select aperture scale or EV scale by holding MODE button and pressing AVE. / ΔEV.

5. Measurement

- "E.u" (Exposure under) or "E.o" (Exposure over) appears when the combination of shutter speed and aperture is outside the display range.

☆ When E.O (Exposure Over) is displayed, it indicates that the measured exposure is outside the display range, changing the shutter speed to a faster setting with the Jog wheel will allow you to find a combination of proper aperture and shutter speed.

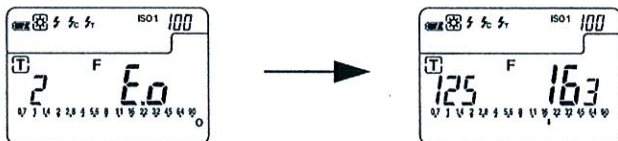

☆ When E.U (Exposure Under) is displayed, it indicates that the measured exposure is outside the display range, changing the shutter speed to a slower shutter speed with the Jog wheel will allow you to find a combination of proper aperture and shutter speed.

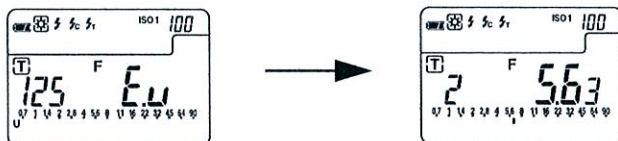

- If the "E.u" or "E.o" readout blinks, this indicates that the light level is beyond the measurement range of the light meter. Adjust lighting in this case.

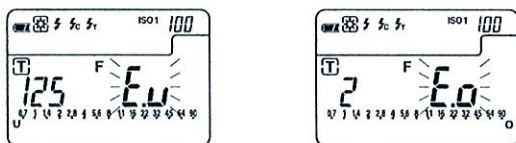

5. Measurement

1-2 Aperture Priority mode

1. Hold down the Mode button (10) and turn the Jog wheel to select aperture priority mode (F).
2. Turn the Jog wheel (5) to set the desired f stop value.

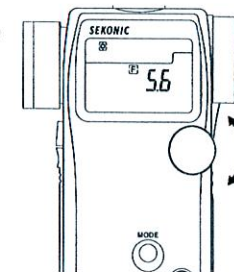

3. Press the Measuring button (14) to take a measurement. Release the Measuring button to complete the measurement. The measured value (shutter speed) at the time will be displayed.

While pressing the Measuring button, the meter measures continuously until it is released.

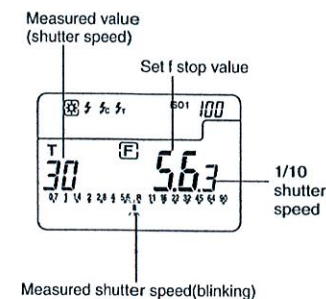



Reference:

- It is possible to switch between full, 1/2 or 1/3 F stop values with the custom setting mode (see page 40).
- You can set aperture from 0.5 to F161. Please note that in 1/3 stop increments F0.56 is displayed as 0.5 and F0.63 is displayed as 0.6.
- EV scale appears on the analog scale. (Shutter speed scale is not displayed.) For details, please see page 48.
- After measurement, the shutter speed corresponding to the F stop is displayed when the F stop is changed with Jog Wheel.
- Readings outside the display range or beyond the measuring range are similar to the previous instruction (see page 16).

5. Measurement

1-3 EV mode

1. To activate EV mode, please set Custom setting no.5 and Item no.1. (See page 40)
2. Hold down the Mode button  and turn the Jog wheel  to select EV mode **EV**.

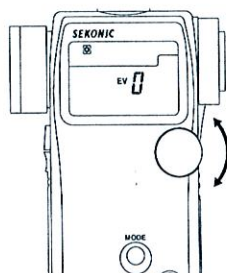

3. Press the Measuring button  to take a measurement. Release the Measuring button to complete the measurement. The measured value (EV=Exposure Value) at that time will be displayed.

At the same time, the shutter speed will be displayed in the digital display area, and the corresponding f stop will be displayed on the analog scale.

While pressing the measuring button, the meter measures continuously until it is released.

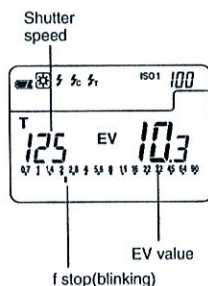



Reference:

- EV (Exposure Value) is the reading that logarithmically expresses the constant quantity of light combined from the shutter speed and aperture value. With 1 EV change the quantity of light doubles (or halves).
- To display EV mode, please set custom setting number 5 and item number 1. (See page 40)
- Readings outside the display range or beyond the measuring range are similar to the previous instruction (see page 16).
- You can select aperture scale or EV scale by holding MODE button and pressing AVE. / Δ EV.

5. Measurement

1-4 Cinematography

1. Hold down the Mode button  and turn the Jog wheel  to select ambient light shutter speed priority mode **T**.

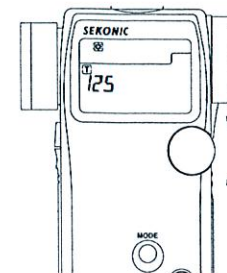

2. Turn the Jog wheel to select the Cine Speed for the camera that will be used. Cine Speed are displayed after 1/8000, 1/200, 1/400 and the unit is in frames per second (f/s).

[L-758DR/758D]

The following Cine Speeds will be displayed:

2, 3, 4, 6, 8, 12, 16, 18, 24, 25, 30, 32, 36, 40, 48, 50, 60, 64, 72, 96, 120, 128, 150, 200, 240, 256, 300 and 360 f/s.

[L-758CINE]

The following Cine Speeds will be displayed:

1, 2, 3, 4, 6, 8, 10, 12, 14, 16, 18, 20, 24, 25, 30, 32, 36, 40, 48, 50, 60, 64, 72, 75, 90, 96, 100, 120, 125, 128, 150, 180, 200, 240, 250, 256, 300, 360, 375, 500, 625, 750 and 1000 f/s.

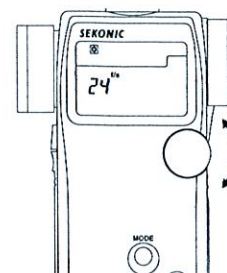

3. The shutter angle that these speeds are based on, is 180 degrees. For other angles make the following ISO sensitivity corrections (L-758DR/758D only).

Shutter angle	Amount of ISO sensitivity correction
160 degrees	-1/3
220 degrees	+1/3

* Example of correction value

-1/3: Decrease ISO sensitivity by 1/3 stop, example: ISO 80 -1/3 stop = ISO 64

+1/3: Increase ISO sensitivity by 1/3 stop, example: ISO 80 +1/3 stop = ISO 100

5. Measurement

5. Measurement

- Setting the shutter angle (L-758CINE only).
It is possible to set the shutter angle by turning the Jog wheel ⑤ while pressing Mode button ⑩ and ISO2 button ⑥.

Note:

- Shutter angle: The angle can be set in the range of 1° to 10° (in 1° steps), 15° - 270° (in 5° steps) as well as, 12° (=11.25°), 17°, 22° (=22.5°), 144° and 172°.
- "Ang" is displayed continuously on the LCD display if the shutter angle is set to any value other than 180°.
- Press both the Mode button and ISO2 button to confirm the shutter angle since it is not displayed.

Reference:

- This setting is only valid when the shutter speed is set to display cine speed (f/s).

- Press the Measuring button ⑭ to take a measurement. Release the Measuring button to complete the measurement. The measured value (f stop value) will be displayed. While pressing the measuring button, the meter measures continuously until it is released.

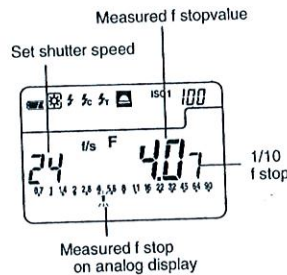

Reference:

- You can select aperture scale or EV scale by holding Mode button and pressing AVE./ ΔEV.
- The L-758DR/758D displays the measured aperture value in either full or 1/3 stop increments on the analog scale from f/0.7 to 90, while L-758CINE displays it in either full or 1/3 stop increments on the analog scale from F0.5 to F64.
- Readings outside the display range or beyond the measuring range are similar to the previous instruction (see page 16).

2. Measuring electronic flash

This method of measurement can be done in the following modes; with cord, without cord, and Wireless flash radio triggering mode (cumulative or non-cumulative). When Measuring flash light, the shutter speed and F stop value (value combining ambient light and flash light: total amount of light) are displayed. The ambient light and flash light are each displayed as separate values together with the total amount of light on the analog scale. In addition, the ratio of flash light to the total amount of light is displayed at that time as a value in 10% steps. The flash reading is displayed as a blinking mark above the analog scale. (See page 27 for details)

2-1 Cord Flash mode

Connect the meter to the flash with a synchro cord. Be sure to replace Synchro terminal cap ⑳ after your measurement.

- Connect the flash synchro cord to the Synchro terminal ⑨ on the light meter.

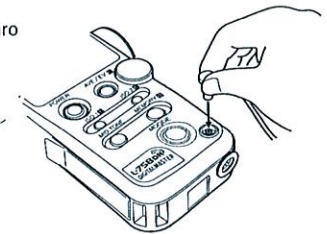

- Hold down the Mode button ⑩ and turn the Jog wheel ⑤ to select cord flash mode ⑫.
- Turn the Jog wheel to set shutter speed. When setting shutter speed, first check the settings to confirm that they correspond to the settings on the camera.

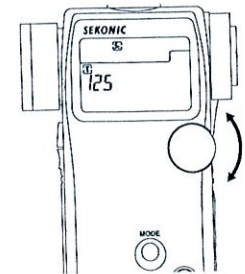

- Press the Measuring button ⑭ to trigger the flash. The measured value (f stop value) will be displayed.

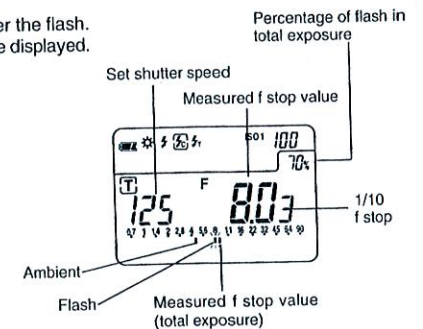

6. Advanced Functions

6. How to use the Exposure compensation function

Exposure compensation can be made in precise 1/10 step increments in a +/- 9.9 EV range. Exposure compensation may be necessary when compensation for filters, bellows, extension tube, etc is required.

1. Set the measurement mode (incident light, reflected light) for the desired compensation. You can make calibration compensation independently for both incident, and reflected light. It is not possible to switch between measurement modes if the setting is not completed.

2. Making a plus compensation will increase the exposure. Hold the ISO1 button (1) and the ISO 2 button (6) and turn the Jog wheel (5) counter clockwise. The  will appear in the upper section of the LCD screen. The compensation will change in +0.1 EV steps up to +9.9.

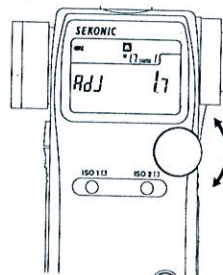



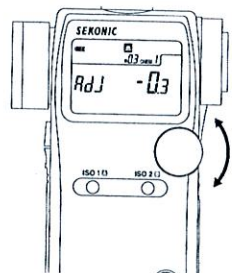

3. Making a minus compensation will decrease the exposure. Hold the ISO1 button and the ISO 2 button and turn the Jog wheel clockwise. The  will appear in the upper section of the LCD screen. The compensation will change in -0.1 EV steps up to -9.9.



NOTE:

- When making compensations, be sure that it satisfies your needs based on the results of your digital camera sensor or film be used.
- While incident and reflected light can be set independently, be aware that both ambient light and flash exposure are corrected uniformly.
- Compensation effects every mode of the meter.
If recalibration has been made for specific purpose do not forget to return to original zero settings.

Reference:

- When compensation is activate, a plus () or minus () sign as well as the amount of compensation is displayed continuously on the LCD. You can set custom settings so that a plus () or minus () sign as well as the amount of compensation doesn't appear on the LCD. (See page 40)
- You can also set custom setting so that making a plus compensation results in a decreased exposure (increasing the value of the aperture or shutter speed value) and making a minus compensation results in and increased exposure (decreasing the value of the aperture or shutter speed).

6. Advanced Functions

7. How to use Calibration compensation function

Calibration compensation can be made in precise 1/10 step increments in a +/- 1.0 EV. It provides the ability to match exposure measurements with meters to meters, correct exposure for special requirements, adjusts for film or digital cameras, etc.

1. Set the measurement mode (incident light, reflected light) for the desired compensation. You can make calibration compensation independently for both incident, and reflected light. It is not possible to switch between measurement modes if the setting is not completed.

2. To enter the calibration setting of the meter it must first be turned off. Press the power button on while holding down the ISO1 and ISO2 buttons simultaneously. You can release the power button, however please keep pressing both ISO1 and ISO2 buttons; the screen will display CAL 0.0 (for calibration).



3. The calibration setting can be changed by rotating the Jog wheel while pressing and holding down the ISO 1 and ISO 2 buttons simultaneously. A range of +/- 1.0 EV in 1/10 step increments is possible for calibration.

NOTE:

- When making calibration compensations, be sure that it satisfies your needs based on the results of digital camera sensor or film being used.
- While incident and reflected light can be set independently, be aware that both ambient light and flash exposure are corrected uniformly.
- Compensation effects every mode of the meter. If recalibration has been made for specific purpose, do not forget to return to original zero settings.

Reference:

- The calibration setting is not displayed on the main screen once it is set.
- You can also set custom setting so that making a plus compensation results in a decreased exposure (increasing the value of the aperture or shutter speed value) and making a minus compensation results in and increased exposure (decreasing the value of the aperture or shutter speed).

6. Advanced Functions

8. Filter compensation

8-1 Filter compensation (1)

It is possible to compensate for filter factor within a range of ± 5.0 EV in 1/10 steps. The measurement corresponding to the set compensation and can be displayed while pressing ISO2 button ⑥. Highlight and shadow compensation values can also be enter for quick exposure metering.

1. Select setting number 1 and item number 1 in the custom setting mode (see page 40).
2. Set the desired compensation by turning the Jog wheel ⑤ while pressing ISO2 button.

- In case of filter compensation

When attaching the filter with 1.0 step exposure factor to the camera, set "1.0" in ISO2 indicator by rotating Jog wheel while pressing ISO2 button.



- In case of highlight measurement compensation

When compensating plus 2 steps from highlight measurement, set "2.0" in ISO2 indicator by rotating Jog wheel while pressing ISO2 button.

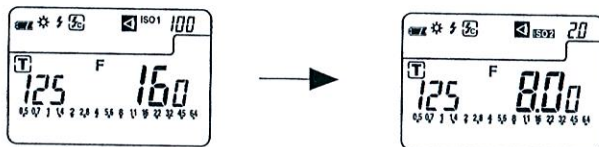

6. Advanced Functions

8-2 Filter factor number compensation (2) (L-758CINE only)

When using the L-758DR for Cine/Video exposures, in cine industry, it is possible to set 7 different frequently used types of filters.

1. Select setting number 1 and item number 2 in the custom setting mode (see page 40).
2. The symbol of the desired filter from among the 7 types can be selected by turning the Jog wheel ⑤ while pressing ISO2 button ⑥.
3. After setting filter compensation, the filter symbol and compensated F value or EV value are displayed while pressing ISO2 button.

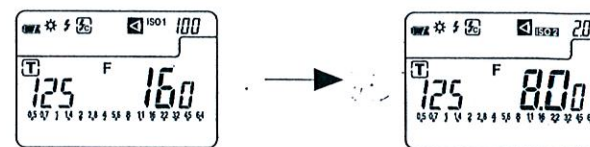

Filters, LCD Display and Corrected Value

Filter Factor No.	85	ND0.3	ND0.6	ND0.9	85N3	85N6	85N9
LCD display	85-	n3-	n6-	n9-	A3-	A6-	A9-
Compensated value (EV)	-0.7	-1	-2	-3	-1.7	-2.7	-3.7

(Filter factor numbers are Kodak Wratten filter numbers.)

6. Advanced Functions

9. Custom setting function

The following Custom Settings provide a quick and easy setup of individual meter preferences. All preferences are stored on a memory chip and can not be deleted, they can only be changed back to default settings.

No.	Model	Custom setting name	Item number			
			0	1	2	3
1	758	ISO 2	Film sensitivity in 1/3 step	Filter compensation (1) in 1/10 step (+/-5EV)	-	-
	CINE		Film sensitivity in 1/3 step	Filter compensation (1) in 1/10 step (+/-5EV)	Filter Factor compensation (2) 7 filter factor numbers	-
2	758 & CINE	Exposure compensation display setting	Always Displayed	Not display	-	-
3 *1	758 & CINE	Increments of Shutter Speed (T) + Aperature (A)	Full step	1/3 step	1/2 step	-
4	758 & CINE	Exposure Priority settings	T + F	T only	F only	-
5	758 & CINE	EV mode	Not available	Available	-	-
6	758 & CINE	Multiple flash mode (cumulative)	Not available	Available	-	-
7	758 & CINE	Dynamic range/ Clipping point icons	Three dots	Within range	Outside range	No display
8	758 & CINE	Standard value if Mid. Tone memory is not set	First memorized value	Current Measured value	Last memorized value	-
9	758 & CINE	Average	Weighted mean average	Simple averaging	-	-
10	758 & CINE	Auto save on Power off	Available	Not available	-	-
11	758 & CINE	Auto power off time	20 min.	10 min.	5 min.	Not available
12	758 & CINE	Jog Wheel Function (clockwise direction)	Decreases value (T or F)	Increases value (T or F)	-	-
13	758 & CINE	Compensation +/- preference	Additive Compensation	Subtractive Compensation	-	-
14 *2	CINE	Illuminance or Luminance display	Selectable individual or Combined	Combined T+F+(Lux /FC) Combined T+F+(FL/cd/m2)	Individual only	-
15	CINE	Illuminance measurement in incident mode	LUX, FC	LUX	FC	Not available
16	CINE	Luminance measurement in reflected mode	cd/m2, FL	cd/m2	FL	Not available
17 *3	758 & CINE	Switching Measuring/ Memory Buttons	Standard	Reverse	Auto-Switching	-

*1 1/10 stop fractions are displayed in full, 1/2 and 1/3 step increments.

*2 Individual: LUX, FC, cd/m² or FL
Compound: LUX+T+F, FC+T+F, cd/m²+T+F or FL+T+F (combination)

*3 Auto-Switching: In incident mode, Measuring/Memory buttons are standard (as they are), however, in reflected mode, automatically two buttons are switched.

Reference:

- Default settings are all set to zero (0).

6. Advanced Functions

- To enter the custom setting mode, the meter must first be turned off. Press Mode button (10) and turn the power on.

- In the custom setting mode, 'CS' (custom setting) is displayed in the ISO display area, a setting number between 01-14 (L-758DR/758D) or 01-17 (L-758CINE) is displayed in the shutter speed display area and item number 0, 1, 2 or 3 is displayed in the aperture display area.

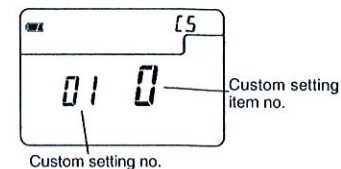

- Turn the Jog wheel (5) and select the desired setting number and the custom setting name (see page 40).

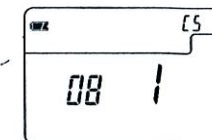

- The item number will change each time the Mode button is pressed.

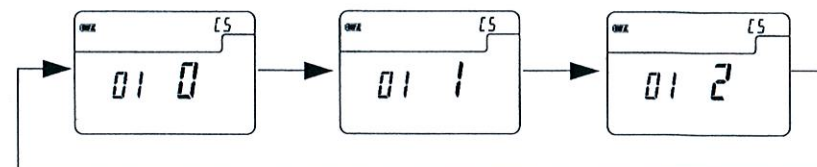

- Pressing the Memory clear button (23) in the custom setting mode will reset all settings to default.

- After completing the custom setting, terminate the custom setting mode by turning the power off. This operation will also automatically turn off the power.